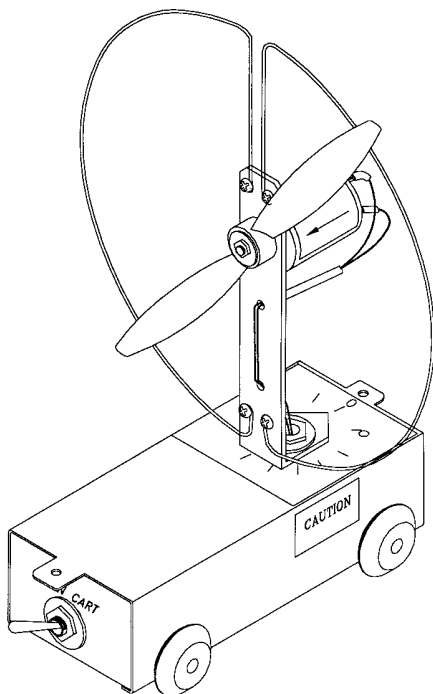


**Instruction Sheet  
for the PASCO  
Model ME-9485**

# FAN CART



## Introduction

The PASCO ME-9485 Fan Cart has the following features:

- The two-speed motor is powered by 4 C-cell batteries.
- The direction of thrust of the fan can be adjusted from zero to 180° to demonstrate force components.
- The cart can be used on a table or floor. Better results are obtained when it is used on the PASCO Dynamics Track (ME-9453 or ME-9480).
- The cart nests on top of the PASCO dynamics cart (ME-9430) to utilize the dynamics cart's plunger and bumpers.
- The sail is attached to the cart by the magnetic strip located on the cart.
- To change the acceleration of the cart, steel masses can be added to the cart by placing them on the magnetic strip.

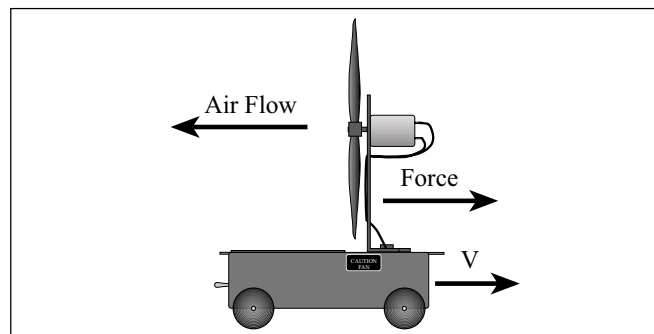
- String can be attached to the tabs on the ends of the cart.
- Approximate mass of fan cart including 4 alkaline batteries = 580g
- Approximate mass of sail = 225g.

### ► CAUTION:

- Keep fingers and other objects away from the moving fan blade.
- We recommend the cart be attached to a fixed object with a safety tether to prevent a runaway cart.

## Demonstration Using the Fan Cart and Sail

1. Place the fan cart at rest on a level dynamics track. To check if the track is level, place the cart on the track and give it a small push in one direction. Then push it in the opposite direction to see if the cart rolls easier in one direction than the other.



**Figure 1: Fan Cart without Sail**

2. Set the fan angle at zero degrees and turn the fan on to show which way the cart moves without the sail. See Figure 1.

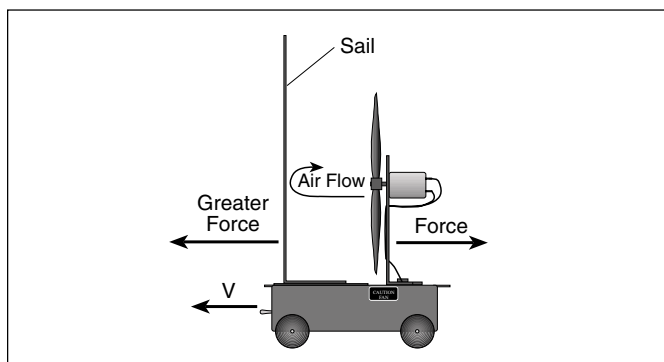
© 1993 PASCO scientific

This instruction sheet written by: Ann Hanks

- Turn the fan off and place the sail on the magnetic pad with the plane of the sail parallel to the plane of the fan.
- Ask the students to predict which direction the cart will move with the sail attached. Turn on the fan to show the direction the cart moves.

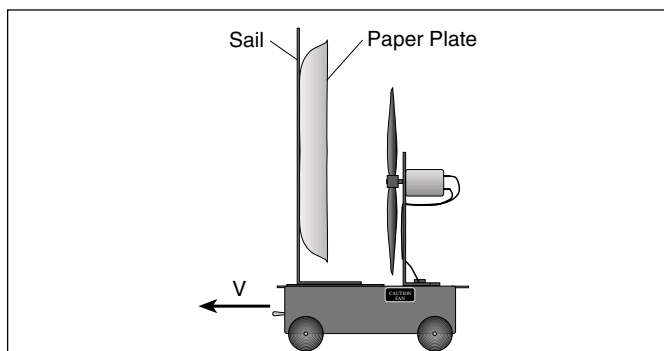
► **NOTE:** Most students will expect the cart not to move. However, the cart will have a small acceleration opposite to the acceleration without the sail.

**Explanation:** There is a force on the cart in one direction resulting from the fan pushing the air and there is another force on the cart in the opposite direction resulting from the air hitting the sail. See Figure 2. But when the air hits the sail, the air bounces off the sail, causing more force on the sail than the force of the air on the fan. Therefore, there is a net force on the cart that causes the cart to accelerate.



**Figure 2: Fan Cart with Sail**

- If you want to increase the effect of the air bouncing off the sail, tape a large paper plate to the sail as shown in Figure 3. The curvature of the paper plate will help reverse the direction of the air.

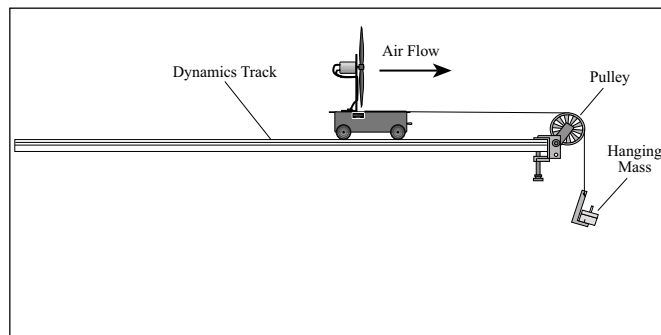


**Figure 3: Fan Cart Sail with paper plate**

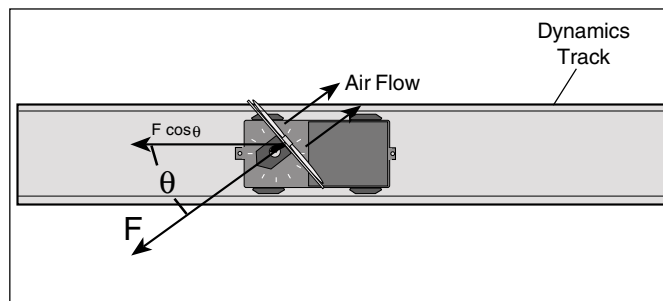
## Suggested Experiments

**Experiment #1:** Use the Motion Sensor or Tape Timer to measure the acceleration of the cart. Add mass and repeat.

**Experiment #2:** Determine the force of the fan by connecting the cart to a mass that hangs over a pulley. Adjust the hanging mass until the cart doesn't move. Then turn the fan at an angle and determine the component of the force. This experiment must be performed on the dynamics track so the cart will go in a straight line. (See Figure 4 and 5)

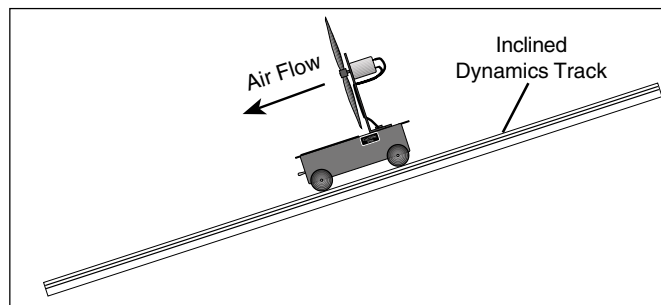


**Figure 4: Fan Cart with hanging mass**



**Figure 5: Fan Cart with Fan at angle**

**Experiment #3:** Put the fan cart on a dynamics track and incline the track until the cart cannot climb the incline. (See Figure 6)



**Figure 6: Fan Cart on incline**

**Experiment #4:** Put the fan cart on top of the PASCO Friction Cart and adjust the friction until the cart goes at constant speed.

## Limited Warranty

PASCO scientific warrants this product to be free from defects in materials and workmanship for a period of one year from the date of shipment to the customer. PASCO will repair or replace, at its option, any part of the product which is deemed to be defective in material or workmanship. This warranty does not cover damage to the product caused by abuse or improper use.

Determination of whether a product failure is the result of a manufacturing defect or improper use by the customer shall be made solely by PASCO scientific. Responsibility for the return of equipment for warranty repair belongs to the customer. Equipment must be properly packed to prevent damage and shipped postage or freight prepaid. (Damage caused by improper packing of the equipment for return shipment will not be covered by the warranty.) Shipping costs for returning the equipment, after repair, will be paid by PASCO scientific.

# Technical Support

## Feed-Back

If you have any comments about this product or this manual please let us know. If you have any suggestions on alternate experiments or find a problem in the manual please tell us. PASCO appreciates any customer feed-back. Your input helps us evaluate and improve our product.

## To Reach PASCO

For Technical Support call us at 1-800-772-8700 (toll-free within the U.S.) or (916) 786-3800, or email: techsupp@PASCO.com

## Contacting Technical Support

Before you call the PASCO Technical Support staff it would be helpful to prepare the following information:

- ▶ If your problem is computer/software related, note:
  - Title and Revision Date of software.
  - Type of Computer (Make, Model, Speed).
  - Type of external Cables/Peripherals.
- ▶ If your problem is with the PASCO apparatus, note:
  - Title and Model number (usually listed on the label).
  - Approximate age of apparatus.
  - A detailed description of the problem/sequence of events. (In case you can't call PASCO right away, you won't lose valuable data.)
  - If possible, have the apparatus within reach when calling. This makes descriptions of individual parts much easier.
- ▶ If your problem relates to the instruction manual, note:
  - Part number and Revision (listed by month and year on the front cover).
  - Have the manual at hand to discuss your questions.